

High Speed 1-Needle Needle  
Feed Lockstitch Industrial Sewing Machine

# DLN-5410N Series

## PARTS LIST

29122306  
No.0903-03

### 1. MACHINE FRAME & MISCELLANEOUS COVER COMPONENTS

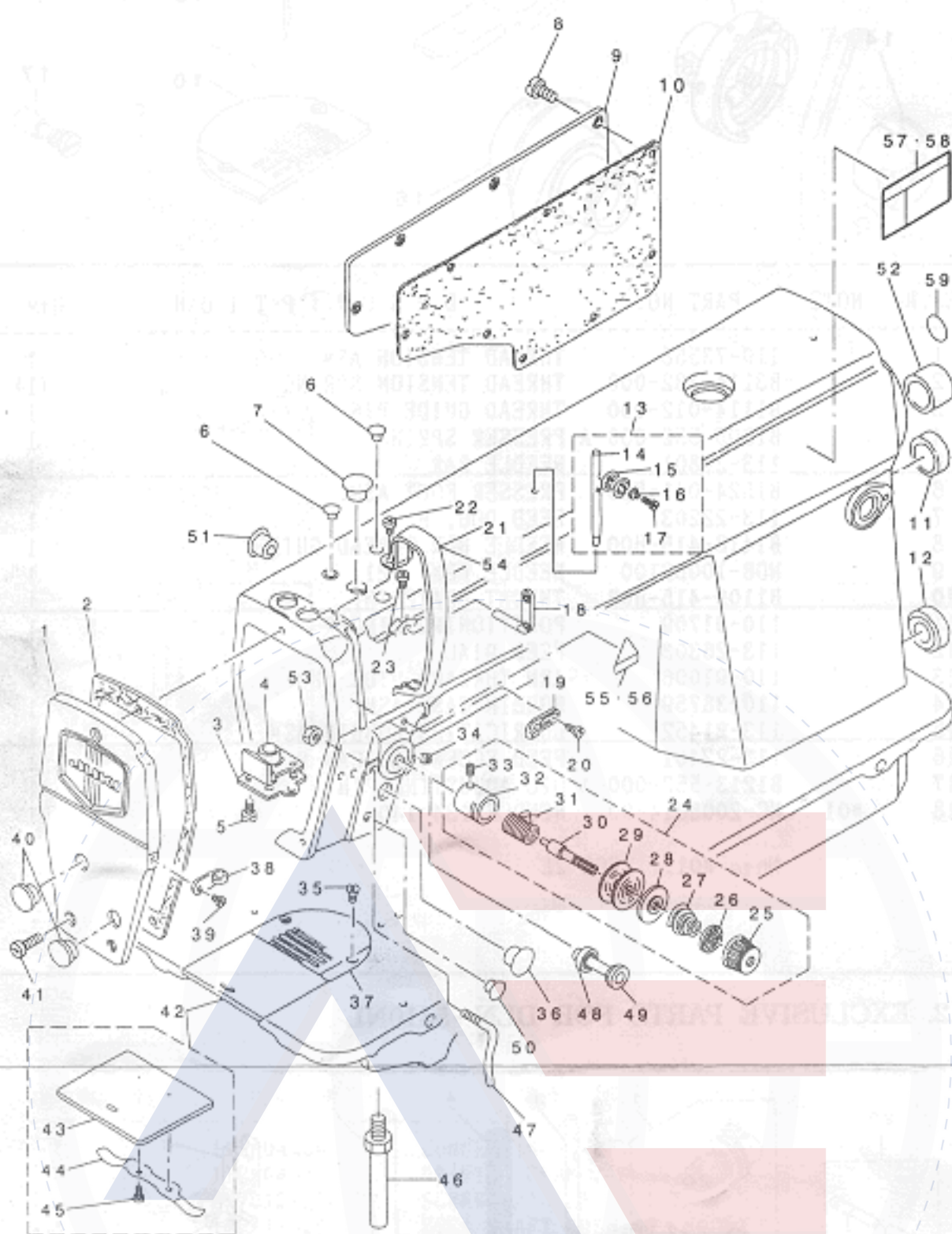

REF. NO.	NOTE	PART NO.	DESCRIPTION	Qty
1		113-25750	FACE PLATE ASM.	1
2		113-00506	FACE PLATE GASKET	1
3		113-00407	PRESSER BAR SUPPORT	1
4		113-00605	GASKET	1
5		SS-1120710-SP	SCREW 3/16-28 L=6.5	4
6		TA-0850604-RO	RUBBER PLUG	2
7		TA-1250705-RO	RUBBER PLUG	1
8		SS-4120915-SP	SCREW 3/16-28 L=9	8
9		110-70901	SIDE PLATE	1
10		110-00610	GASKET	1
11		TA-2000502-RO	RUBBER PLUG	1
12		TA-2101002-RO	RUBBER PLUG	1
13		B1113-155-0A0	NEEDLE THREAD GUIDE PIN ASM.	1
14		B1113-155-000	NEEDLE THREAD GUIDE PIN	(1)
15		B3148-123-000	TENSION DISC	(2)
16		B3149-123-A00	TENSION SPRING	(1)
17		SD-0380552-SL	HINGE SCREW D=3.8 H=5.5	(1)
18		110-18702	TWO-HOLE THREAD EYELET	1
19		110-18504	ARM THREAD GUIDE A	1
20		110-01500	SCREW	1
21		114-00405	THREAD TAKE-UP LEVER COVER	1
22		SS-4120615-SP	SCREW 3/16-28 L=6	1
23		SS-4120615-SP	SCREW 3/16-28 L=6	1
24		110-72253	THREAD TENSION ASM.	1
25		110-72204	TENSION NUT	(1)
26		B3120-125-000	ROTATING STOPPER	(1)
27		B3120-012-A00	TENSION SPRING	(1)
28		B3132-552-000	THREAD TENSION DISK PRESSER	(1)
29		B3126-012-000	THREAD TENSION DISK	(2)
30		B3115-552-000	TENSION POST	(1)
31		B3128-012-000	TAKE-UP SPRING	(1)
32		B3111-552-800	TENSION POST SOCKET	(1)
33		SS-8090670-SP	SCREW 9/64-40 L= 5.5	(1)
34		SS-8150710-SP	SCREW 15/64-28 L=7	1
35		SS-2110820-TP	SCREW 11/64-40 L=8.5	2
36		TA-1250504-RO	RUBBER PLUG	1
37		113-00308	THROAT PLATE	1
38		110-18603	ARM THREAD GUIDE B	1
39		SS-6110610-TP	SCREW 11/64-40 L=8	1
40		TA-1250408-RO	RUBBER PLUG D=12.5 L=4	2
41		SS-4121015-SP	SCREW 3/16-28 L=10	3
42		110-01658	BED SLIDE ASM.	1
43		B1110-012-000	SLIDE PLATE	(1)
44		110-01609	BED SLIDE SPRING	(1)
45		SS-6060210-SP	SCREW 3/32-56 L= 1.9	(2)
46		110-01104	BED SCREW STUD	4
47		113-05513	ARM THREAD GUIDE, C	1
48		B3133-415-0A0	TENSION RELEASE PIN CAP	1
49		B3136-415-000	CAP RING	1
50		TA-0850604-RO	RUBBER PLUG	1
51		TA-1250504-RO	RUBBER PLUG	1
52		TA-2101002-RO	RUBBER PLUG	1
53		NS-6090310-SP	NUT 9/64-40	1
54	#01	180-077503	THREAD TAKE-UP LEVER COVER	1
55	#01	CM-3002000-01	ATTENTION SEAL	1
56	#02	CM-3002000-B1	LABEL (16)	1
57	#02	CM-3002001-01	SAFETY LABEL, 1 (SMALL).	1
58	#03	CM-3002001-A1	SAFETY LABEL, 3 (SMALL).	1
59		100-04109	GROUND MARK	1

Note #01....FOR JE  
#02....FOR DOMESTIC USE  
#03....EXCEPT JE, DOMESTIC USE

## 2. MAIN SHAFT & THREAD TAKE-UP LEVER COMPONENTS

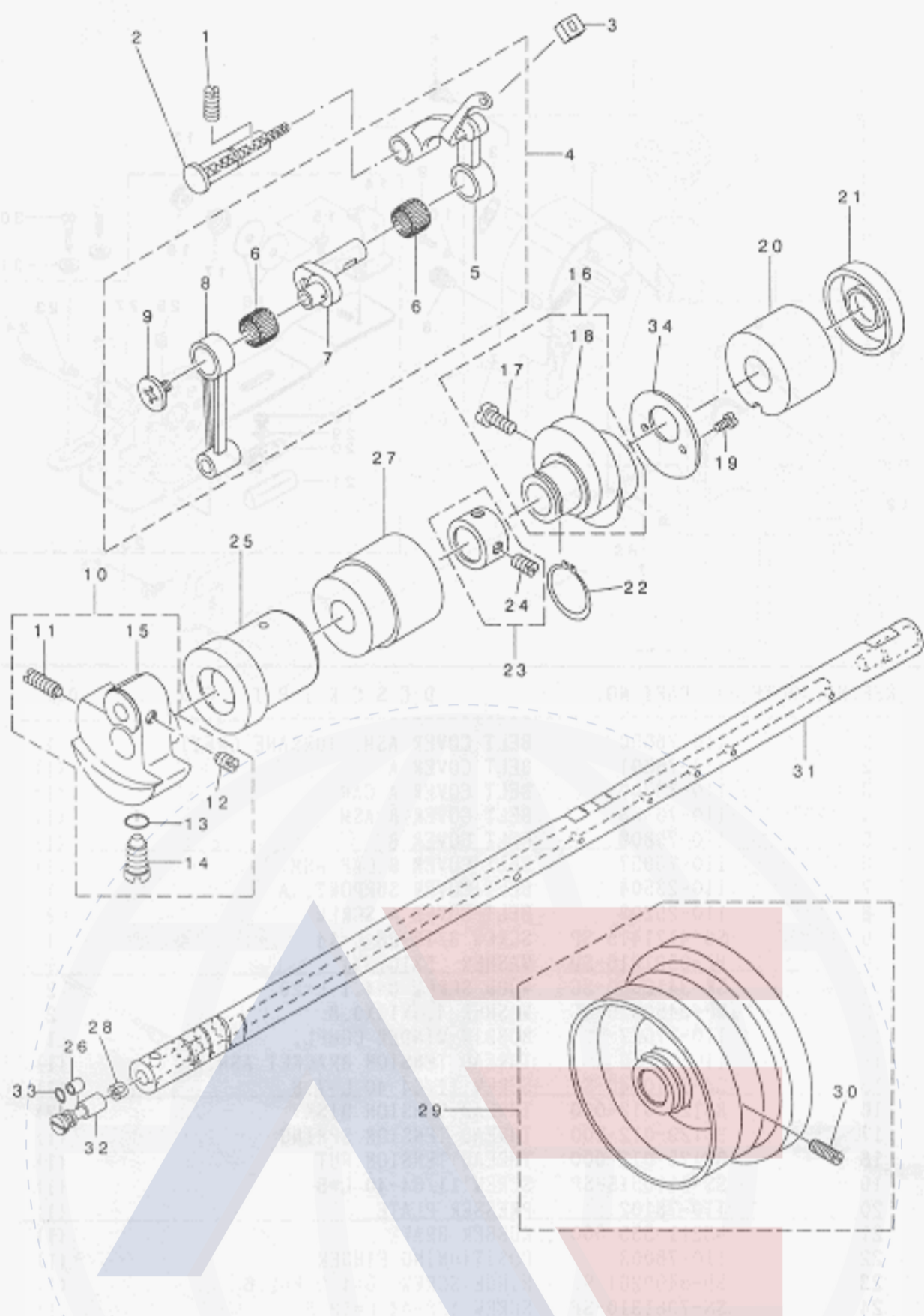

REF. NO	NOTE	PART NO.	DESCRIPTION	Qty
1		SS-8151150-SP	SCREW 15/64-28 L=10.5	1
2		110-17357	THREAD TAKE-UP CRANK SHAFT ASH	1
3		B1909-505-000	RUBBER	1
4		110-39070	THREAD TAKE-UP LEVER ASM.	1
5		110-39062	THREAD TAKE-UP LEVER ASM.	(1)
6	#01	B1905-541-B00	NEEDLE BEARING	(2)
7		110-05204	NEEDLE BAR CRANK	(1)
8		B1408-552-000	NEEDLE BAR CRANK ROD	(1)
9		B1903-552-000	LEFT SCREW	(1)
10		110-02169	COUNTERWEIGHT ASM.	1
11		SS-8681650-TP	SCREW 9/32-28 L=16	(1)
12		SS-8660610-TP	SCREW 1/4-40 L=6	(2)
13		RO-0442401-00	RUBBER RING	(1)
14		SS-7681650-TP	SCREW 9/32-28 L=16	(1)
15		110-02110	COUNTER WEIGHT	(1)
16		113-02353	FEED DRIVE ECCENTRIC CAM ASM.	1
17		SS-8661110-SP	SCREW 1/4-40 L=11	(2)
18		113-02304	FEED DRIVE ECCENTRIC CAM	1
19		SS-6090650-SP	SCREW 9/64-40 L=6	2
20		110-02409	MAIN SHAFT BUSHING, REAR	1
21		110-02508	OIL SEAL	1
22		RC-1850001-KP	SNAP RING 18.5	1
23		CS-147121A-SH	THRUST COLLAR ASM. D=14.72 W=12	1
24		SS-8660610-TP	SCREW 1/4-40 L=6	(2)
25		113-00902	BUSHING, FRONT	1
26		B1215-552-000	OIL ADJUSTING COLLAR	1
27		112-02306	BUSHING, INTERMEDIATE	1
28		110-02904	ROLLER FELT	1
29		110-71354	FLYWHEEL ASM.	1
30		SS-8151550-SP	SCREW 15/64-28 L=15	(2)
31		110-02003	MAIN SHAFT	1
32		110-03001	OIL AMOUNT ADJUSTING COLLAR	1
33		RO-0291801-00	RUBBER RING	1
34		110-08109	THRUST COLLAR	1

Note #01....SELECTIVE PART

### 3. NEEDLE BAR, UPRIGHT SHAFT & HOOK DRIVING SHAFT COMPONENTS

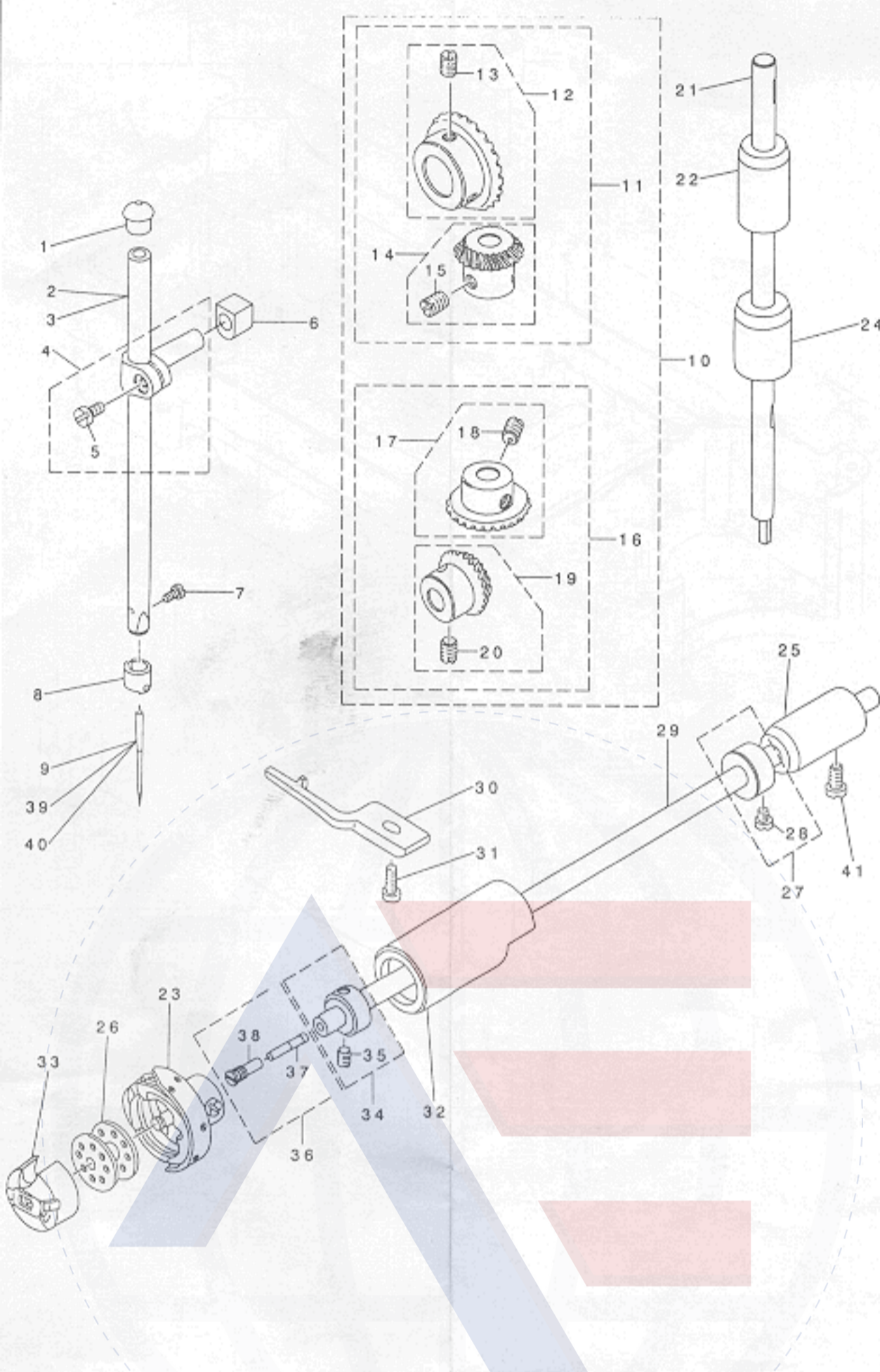

REF.NO	NOTE	PART NO.	DESCRIPTION	Qty
1		TA-1250804-RO	RUBBER PLUG	1
2		113-01009	NEEDLE BAR, A	1
3	#01	113-01108	NEEDLE BAR, B	1
4		B1411-552-0A0	NEEDLE ROD HOLDER ASM.	1
5		SS-6090670-TP	SCREW 9/64-40 L=6	(1)
6		B1414-226-000	SLIDE BLOCK	1
7		SS-7080510-TP	SCREW 1/8-44 L=4.5	1
8		B1418-552-A00	NEEDLE THREAD GUIDE A	1
9		MDB-100B1400	NEEDLE DBX1 #14	1
10		B1306-155-0C0	GEAR & PINION ASM.	1
11		B1306-155-0B0	GEAR & PINION ASM., UPPER	(1)
12		B1305-012-0A0	GEAR ASM.	(1)
13		SS-8660810-TP	SCREW 1/4-40 L=8	(2)
14		B1306-155-0A0	PINION ASM.	(1)
15		SS-8660810-TP	SCREW 1/4-40 L=8	(2)
16		B1307-155-0B0	GEAR & PINION ASM., LOWER	(1)
17		B1307-155-0A0	GEAR ASM. LARGE	(1)
18		SS-8660810-TP	SCREW 1/4-40 L=8	(2)
19		B1308-155-0A0	PINION ASM.	(1)
20		SS-8660810-TP	SCREW 1/4-40 L=8	(2)
21		110-04009	UPRIGHT SHAFT	1
22		110-04306	BUSHING B, UPPER	1
23		B1830-415-0A0	HOOK ASM.	1
24		110-04207	UPRIGHT SHAFT BUSHING, LOWER	1
25		110-15807	BUSHING, REAR	1
26		B9117-012-000	BOBBIN	1
27		CS-079101A-SH	THRUST COLLAR ASM. D=7.94 W=10	1
28		SS-6110420-TP	SCREW 11/64-40 L=4.8	(2)
29		110-15005	HOOK DRIVING SHAFT	1
30		110-38809	BOBBIN CASE HOLDER	1
31		SS-6111010-SP	SCREW 11/64-40 L= 9.5	1
32		110-15104	BUSHING ASM., FRONT	1
33		B1837-012-0A0	BOBBIN CASE ASM.	1
34		CS-079073A-SH	THRUST COLLAR ASM.	1
35		SS-8110410-TP	SCREW 11/64-40 L= 3.5	(2)
36		110-15955	OIL SEAL SCREW ASM.	1
37		110-15906	OIL WICK	(1)
38		B1808-552-000	OIL SEAL SCREW	(1)
39	#02	MC-2005009-00	NEEDLE 134 90	1
40	#03	MDP-500B1400	NEEDLE DPX5 #14	1
41		SS-4120915-SP	SCREW 3/16-28 L=9	1

Note #01....FOR JE,JO  
 #02....FOR JE  
 #03....FOR JO

#### 4. HAND LIFTER COMPONENTS

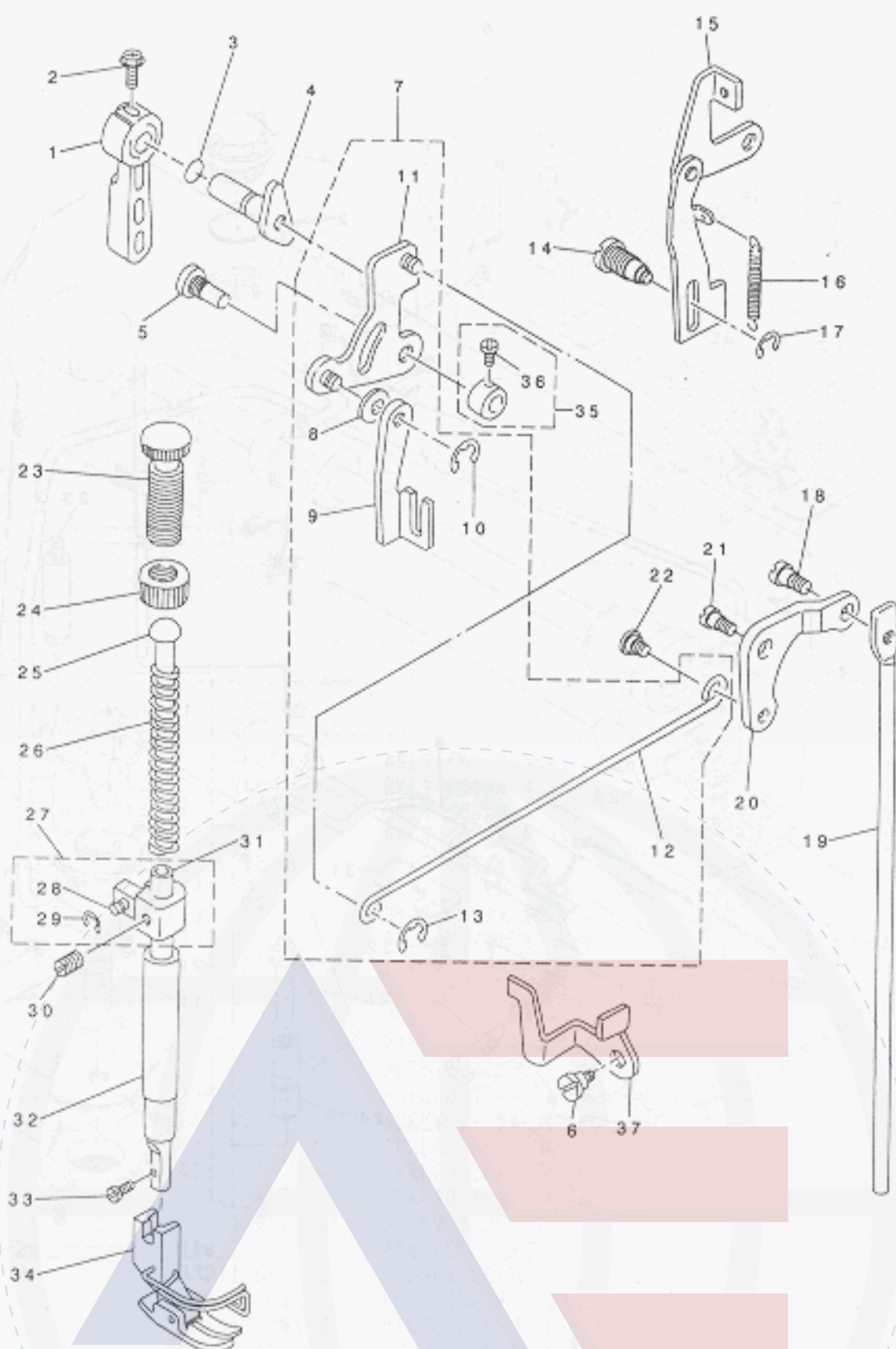

REF.NO	NOTE	PART NO.	DESCRIPTION	Qty
1		110-71800	HAND LIFTER	1
2		B1521-555-000	SCREW	1
3		RO-0371801-00	RUBBER RING	1
4		110-06756	HAND LIFTER CAM ASM.	1
5		113-01702	LINK SHAFT	1
6		SD-0640261-SP	HINGE SCREW D=3.65 H=2.6	1
7		113-01652	LIFTING LEVER ASM.	1
8		WP-0650876-SD	WASHER 6.5X13X0.8	(1)
9		113-01603	LIFTING LEVER	(1)
10		RE-0500000-KO	E-RING	(1)
11		110-06350	HAND LIFTER LINK	(1)
12		110-06905	LIFTING LEVER CONNECTING ROD	(1)
13		RE-0500000-KO	E-RING	(1)
14		113-06107	TENSION RELEASE PLATE SHAFT	1
15		113-05653	TENSION RELEASE PLATE ASM.	1
16		113-05901	SPRING	1
17		RE-0300000-KO	E-RING 3	1
18		SD-0600322-SD	HINGE SCREW D=6 H=3.2	1
19		112-05408	CONNECTING ROD	1
20		112-05309	LIFTING LEVER LINK	1
21		SD-0720331-SP	HINGE SCREW D= 7.24 H= 3.3	1
22		110-07101	HINGE SCREW	1
23		110-71602	PRESSER SPRING REGULATOR	1
24		110-71701	NUT	1
25		B1510-227-000	PRESSER GUIDE BAR	1
26		B1505-227-000-A	PRESSER SPRING	1
27		113-01355	NEEDLE BAR GUIDE BRACKET ASM.	1
28		113-01405	PIN	(1)
29		RE-0300000-KO	E-RING 3	(2)
30		SS-8660610-TP	SCREW 1/4-40 L=6	1
31		B1501-127-000	PRESSER BAR	1
32		B1502-541-000	PRESSER BAR BUSHING, LOWER	1
33		SS-7091110-SP	SCREW 9/64-40 L=10.5	1
34		D1524-415-BBC	PRESSER FOOT ASM.	1
35		CS-064061A-SP	THRUST COLLAR ASM.	1
36		SS-7090620-TP	SCREW 9/64-40 L=6.1	(1)
37		113-05703	TENSION RELEASE LINK, A	1

# 5. FEED MECHANISM COMPONENTS

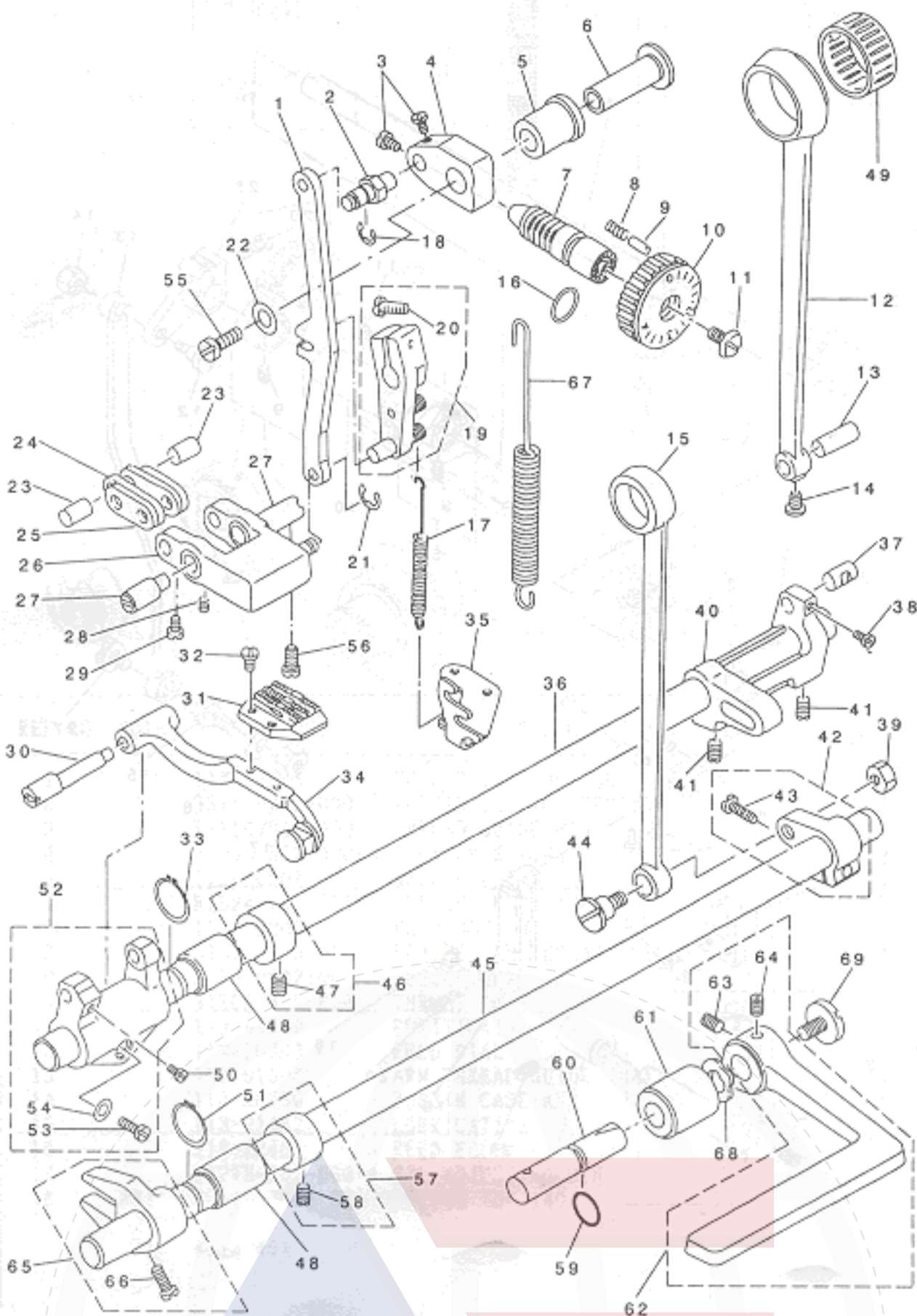

REF. NO	NOTE	PART NO.	DESCRIPTION	Qty
1		113-02106	FEED ADJUST ROD	1
2		113-02817	PIN	1
3		SS-6090560-TP	SCREW 9/64-40 L=4.5	2
4		113-03328	FEED REGULATOR BUSHING	1
5		110-11509	FEED REGULATOR BUSHING	1
6		113-85127	FEED REGULATOR SHAFT	1
7		110-09909	FEED REGULATOR SCREW	1
8		B1148-555-000	SPRING	1
9		110-52701	PIN	1
10		113-26204	FEED DIAL	1
11		SS-6121860-SP	SCREW 3/16-28 L=18	1
12		113-02411	ROCKER SHAFT CONNECTING ROD	1
13		110-09206	WALKING FOOT PIN C	1
14		SS-6090620-SP	SCREW 9/64-40 L=6	1
15		110-14008	CONNECTING ROD	1
16		RD-0922702-00	RUBBER RING	1
17		113-05000	SPRING	1
18		RE-0500000-K0	E-RING	1
19		113-02254	FEED REVERSE ARM ASM.	1
20		SS-7121410-TP	SCREW 3/16-28 L=14	(1)
21		RE-0500000-K0	E-RING	1
22		WP-0702026-SP	WASHER 7X15X2	1
23		110-09008	WALKING FOOT PIN A	2
24		113-03005	CONNECTING LINK, B	2
25		113-02908	CONNECTING LINK, A	2
26		113-03161	FEED ADJUST LINK ASM.	1
27		110-08802	ADJUSTING LINK FULCRUM SHAFT A	2
28		SS-8150710-SP	SCREW 15/64-28 L=7	1
29		SS-6090620-SP	SCREW 9/64-40 L=6	2
30		110-11103	FEED BAR SHAFT	1
31		D1609-415-B00	FEED DOG	1
32		SS-4080620-TP	SCREW 1/8-44 L=6	2
33		RC-0150001-KP	RETAINING RING 13.8	1
34		110-11251	FEED BAR ASM.	1
35		113-01900	FEED SPRING HOOK	1
36		110-10808	FEED ROCKER SHAFT	1
37		110-09107	WALKING FOOT PIN B	1
38		SS-6090620-SP	SCREW 9/64-40 L=6	1
39		NS-6680410-SP	NUT 9/32-28	1
40		113-02502	FEED ROCKER SHAFT CRANK	1
41		SS-8681130-SP	SCREW 9/32-28 L=11	2
42		110-14156	REAR CRANK ASM.	1
43		SS-7121610-SP	SCREW 3/16-28 L=15.5	(1)
44		SD-1000801-SH	HINGE SCREW D=10 H=8	1
45		110-14206	FEED DRIVING SHAFT	1
46		CS-147121A-SH	THRUST COLLAR ASM. D=14.72 W=12	1
47		SS-8660610-TP	SCREW 1/4-40 L=6	(2)
48		110-10907	FEED ROCKER SHAFT BUSHING	2
49	#01	B1636-581-C00	NEEDLE BEARING	1
50		SS-7110740-TP	SCREW 11/64-40 L=7	1
51		RC-0150001-KP	RETAINING RING 13.8	1
52		110-11053	FEED ROCKER ASM.	1
53		SS-7121410-TP	SCREW 3/16-28 L=14	(1)
54		WP-0480856-SP	WASHER 4.8X8.4X0.8	(1)
55		SS-9661120-CP	SCREW 1/4-40 L=10.5	1
56		SS-6151220-SP	SCREW 15/64-28 L=11.5	1
57		CS-147121A-SH	THRUST COLLAR ASM. D=14.72 W=12	1
58		SS-8660610-TP	SCREW 1/4-40 L=6	2
59		RD-0781901-00	RUBBER RING	1
60		110-53105	FEED REVERSE SHAFT	1
61		110-10709	FEED LEVER METAL	1
62		110-72154	FEED LEVER ASM.	1
63		SS-8661030-SP	SCREW 1/4-40 L=10	(1)
64		SS-8661040-TP	SCREW 1/4-40 L=10	(1)
65		110-14354	DRIVING SHAFT CRANK ASM.	1
66		SS-7111120-SP	SCREW 11/64-40 L=10.5	(1)
67		113-02619	SPRING	1
68		WZ-1250300-K0	WAVED WASHER 12.5X17X0.3	1
69		SS-7620750-SP	SCREW 3/16-32 L= 6.5	1

Note #01...SELECTIVE PART

# 6. NEEDLE BAR FRAME COMPONENTS

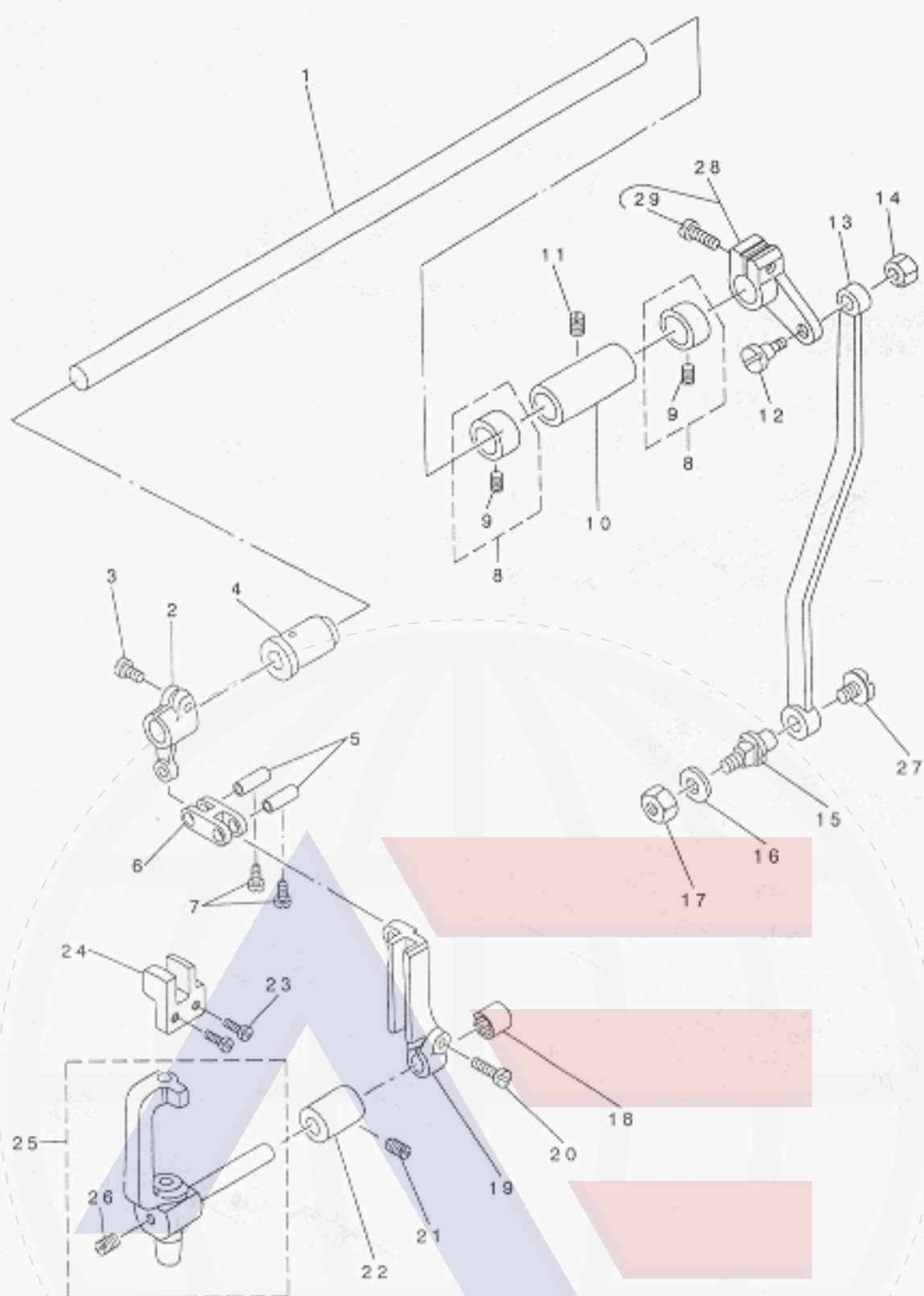

REF. NO	NOTE	PART NO.	DESCRIPTION	Qty
1		113-04409	CONNECTING SHAFT	1
2		113-04003	DRIVING CRANK, FRONT	1
3		SS-6121220-TP	SCREW 3/16-28 L=11.5	1
4		112-11000	ROCK SHAFT BUSHING, FRONT	1
5	#01	B1412-352-B00	NEEDLE BAR LINK PIN	2
6		B2906-415-000	DRIVING LINK	1
7		SS-6090660-TP	SCREW 9/64-40 L=6	2
8		CS-120101B-SH	THRUST COLLAR ASM.	2
9		SS-8660410-SP	SCREW 1/4-40 L= 4.2	(4)
10		112-10903	ROCK SHAFT BUSHING, REAR	1
11		SS-8120740-SP	SCREW 3/16-28 L=7	1
12		SD-0790501-SP	HINGE SCREW D=7.94 H=5	1
13		113-04201	CONNECTING ROD	1
14		NS-6150310-SP	NUT 15/64-28	1
15		113-04300	CONNECTING ROD SHAFT	1
16		WP-0621016-SD	WASHER 6.2X13X1	1
17		NS-6150430-SP	NUT 15/64-28	1
18		SB-3090004-00	BEARING	1
19		113-03807	SLIDE BLOCK GUIDE	1
20		SS-6121610-SP	SCREW 3/16-28 L=15.5	1
21		SS-8120740-SP	SCREW 3/16-28 L=7	1
22		112-14509	BUSHING	1
23		SS-6090810-SP	SCREW 9/64-40 L= 7.5	2
24		113-03906	NEEDLE BAR FRAME GUIDE	1
25		113-03567	NEEDLE ROD ROCKING BASE ASM.	1
26		SS-8110310-SP	SCREW 11/64-40 L= 2.8	(1)
27		SS-6110640-SP	SCREW 11/64-40 L=6	(1)
28		113-04151	SHAFT ARM ASM. (REAR)	1
29		SS-7121410-SP	SCREW 3/16-28 L=14	(1)

Note #01....SELECTIVE PART

# 7. OIL LUBRICATION COMPONENTS

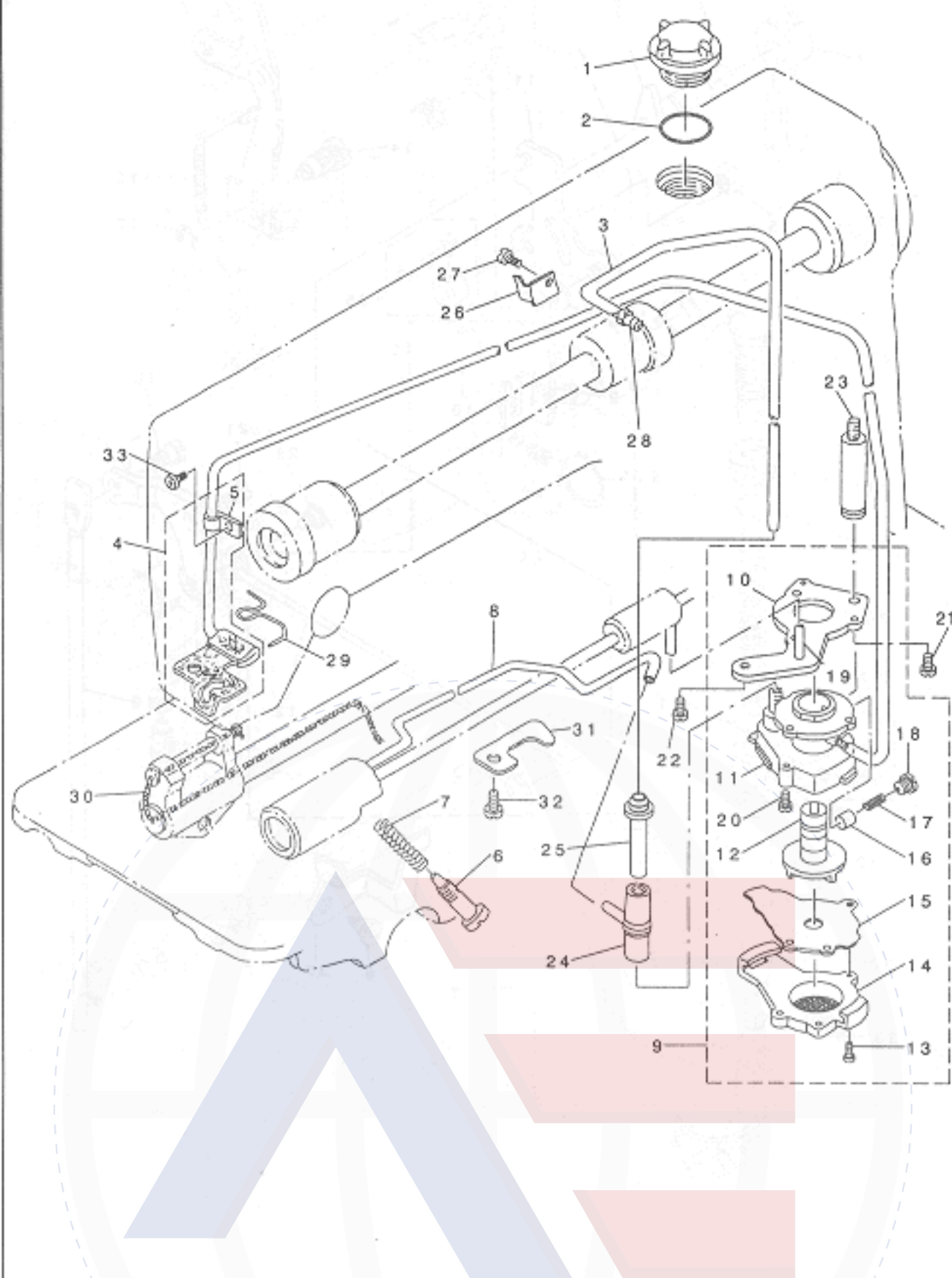

REF. NO	NOTE	PART NO.	DESCRIPTION	Qty
1		B3530-555-000	OIL SIGHT WINDOW	1
2		RO-1952401-00	RUBBER RING	1
3		BT-0600402-EA	OIL TUBE	0.26
4		113-07154	OIL RETURN TUBE ASM.	1
5		B3536-122-000	HOLDER	(1)
6		B3514-412-000	OIL ADJUSTING SCREW	1
7		B2616-372-000	SPRING	1
8		113-07352	OIL WICK ASM.	1
9		110-20054	LUBRICATING OIL PUMP ASM.	1
10		110-20302	OIL PUMP INSTALLING BASE	(1)
11		110-20005	OIL PUMP	(1)
12		110-20708	OIL PUMP IMPELLER	(1)
13		SE-4301041-SR	SCREW D=3 L=10	(3)
14		110-20203	LUBRICATING OIL PUMP COVER	(1)
15		110-20807	OIL PUMP IMPELLER COVER	(1)
16		110-20401	PLUNGER	(1)
17		110-20609	PLUNGER SPRING	(1)
18		110-20500	PLUNGER SCREW	(1)
19		110-20906	HOOK DRIVING SHAFT OIL TUBE	(1)
20		SL-4030851-SF	SCREW M3 L=8	(3)
21		SS-6111010-TP	SCREW 11/64-40 L= 9.5	1
22		SS-4150915-SP	SCREW 15/64-28 L=9	1
23		113-92107	OIL PUMP SUPPORT	1
24		110-21409	RUBBER JOINT	1
25		112-21504	OIL TUBE JOINT	1
26		112-22007	HOLDER	1
27		SS-6080340-SP	SCREW 1/8-44 L=2.9	1
28		SQ-1150501-SD	CONNECTING SCREW	1
29		113-07006	OIL FELT PRESSER	1
30		CQ-2520000-00	OIL WICK	0.21
31		110-21706	TUBE HOLDER (LOWER)	1
32		SS-4120615-SP	SCREW 3/16-28 L=6	1
33		SS-4120615-SP	SCREW 3/16-28 L=6	1

## 8. OIL RESERVOIR COMPONENTS

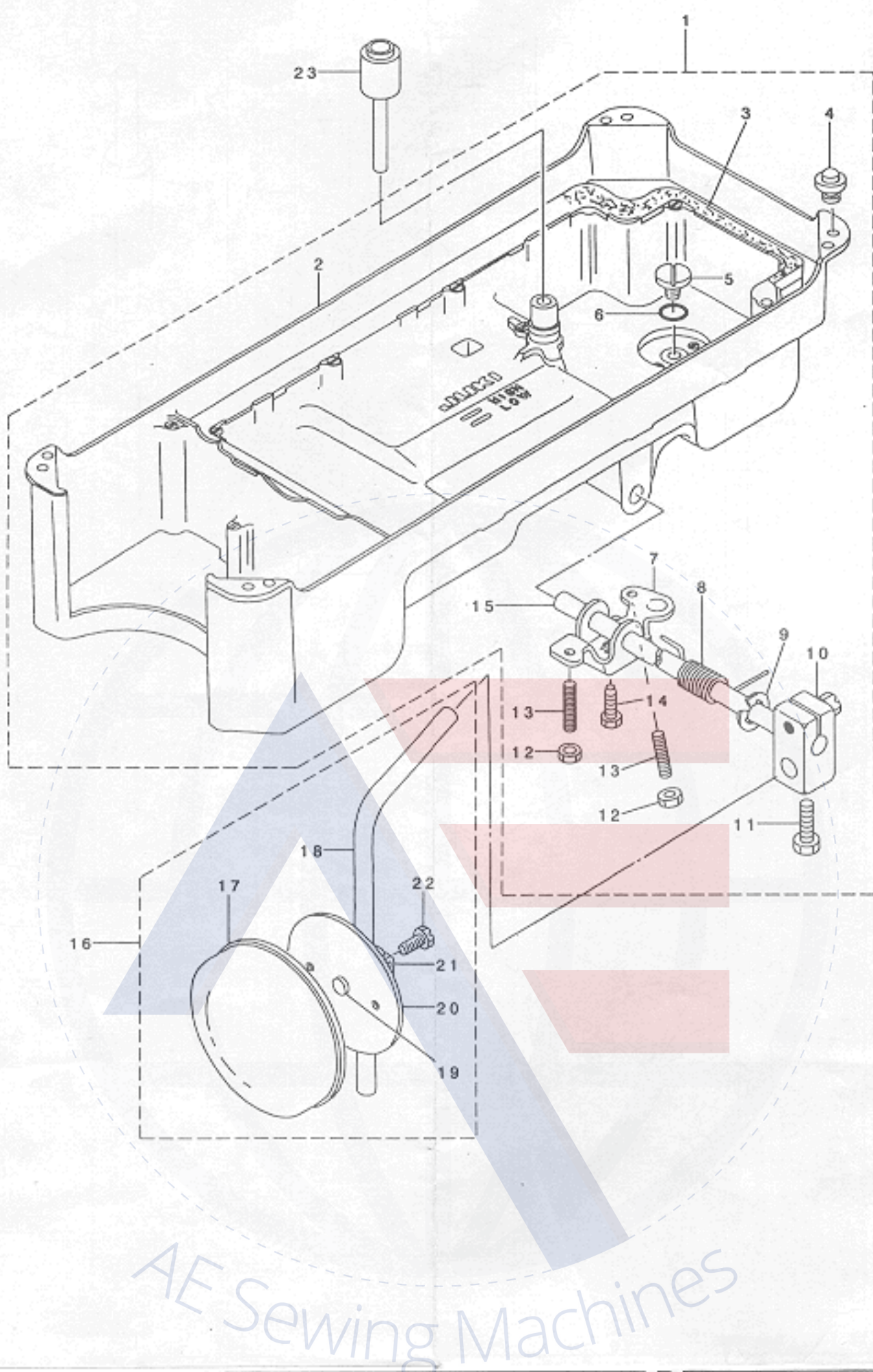

REF.NO	NOTE	PART NO.	DESCRIPTION	Qty
1		110-47057	OIL RESERVOIR ASH.	1
2		110-23017	OIL RESERVOIR	(1)
3		110-24700	GASKET	(1)
4		110-47107	RUBBER CUSHION	(4)
5		SS-6700710-SH	SCREW 5/16-24 L=7	(1)
6		RO-1082401-00	RUBBER RING	(1)
7		110-24015	CONNECTING ROT. VERTICAL	(1)
8		110-24106	SPRING	(1)
9		RE-1000000-K0	E-RING 10	(1)
10		110-24510	BRACKET	(1)
11		SM-9062053-SR	SCREW M6 L=20	(2)
12		NH-6060001-SE	NUT M6	(2)
13		SM-8063012-TR	SCREW M6 L=30	(2)
14		SM-9061853-SR	SCREW M6 L=17.5	(1)
15		110-24205	KNEE PRESS ROD	(1)
16		110-23751	KNEE PRESS PLATE ASH.	1
17		B3431-552-000-A	KNEE PRESS PLATE COVER	(1)
18		B3419-122-000	KNEE LIFTER PLATE ROD	(1)
19		110-24403	RUBBER	(1)
20		110-23702	KNEE PRESS PLATE	(1)
21		110-23801	KNEE PRESS PLATE HOLDER	(1)
22		SM-9061203-SE	SCREW M6 L=12	(1)
23		110-24304	KNEE PRESS LIFTER ROD	1



# 9. BELT COVER & BOBBIN WINDER COMPONENTS

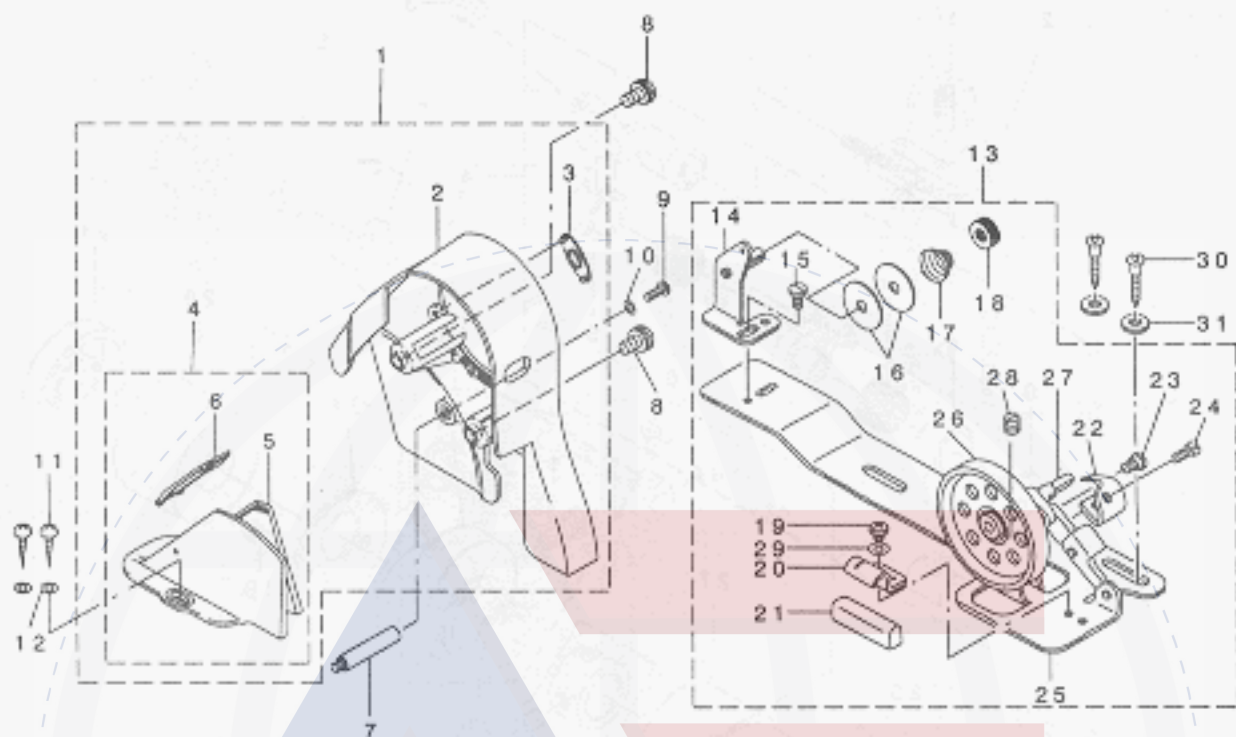

REF. NO	NOTE	PART NO.	DESCRIPTION	Qty
1		110-76650	BELT COVER ASM. (URBANE GREY)	1
2		110-76601	BELT COVER A	(1)
3		110-76700	BELT COVER A CAP	(1)
4		110-76858	BELT COVER B ASM.	(1)
5		110-76809	BELT COVER B	(1)
6		110-76957	BELT COVER B CAP ASM.	(1)
7		110-23504	BELT COVER SUPPORT, A	1
8		110-25202	BELT COVER A SCREW	2
9		SS-4121415-SP	SCREW 3/16-28 L=14	1
10		WP-0501016-SD	WASHER 5X10.5X1	1
11		SK-3412000-SC	WOOD SCREW D=4.1 L=20	2
12		WP-0450826-SC	WASHER 4.5X10X0.8	2
13		110-77567	BOBBIN WINDER COMPL.	1
14		110-78250	THREAD TENSION BRACKET ASM.	(1)
15		SS-7110840-SP	SCREW 11/64-40 L=7.8	(1)
16		B3126-012-000	THREAD TENSION DISK	(2)
17		B3129-012-B00	THREAD TENSION SPRING	(1)
18		B3125-012-000	THREAD TENSION NUT	(1)
19		SS-4110515-SP	SCREW 11/64-40 L=5	(1)
20		110-78102	PRESSER PLATE	(1)
21		B3211-555-000	RUBBER BRAKE	(1)
22		110-78003	POSITIONING FINGER	(1)
23		SD-0490261-SP	HINGE SCREW D=4.9 H=2.6	(1)
24		SS-7081310-SP	SCREW 1/8-44 L=12.5	(1)
25		110-77500	BOBBIN BASE	(1)
26		110-77609	BOBBIN PULLEY	(1)
27		B3204-555-000	BOBBIN WINDER POST	(1)
28		SH-8040502-TP	SCREW M4X0.7 L=5	(1)
29		WP-0480856-SP	WASHER 4.8X8.4X0.8	(1)
30		SK-3412000-SC	WOOD SCREW D=4.1 L=20	2
31		WP-0450826-SC	WASHER 4.5X10X0.8	2

# 10. THREAD STAND COMPONENTS

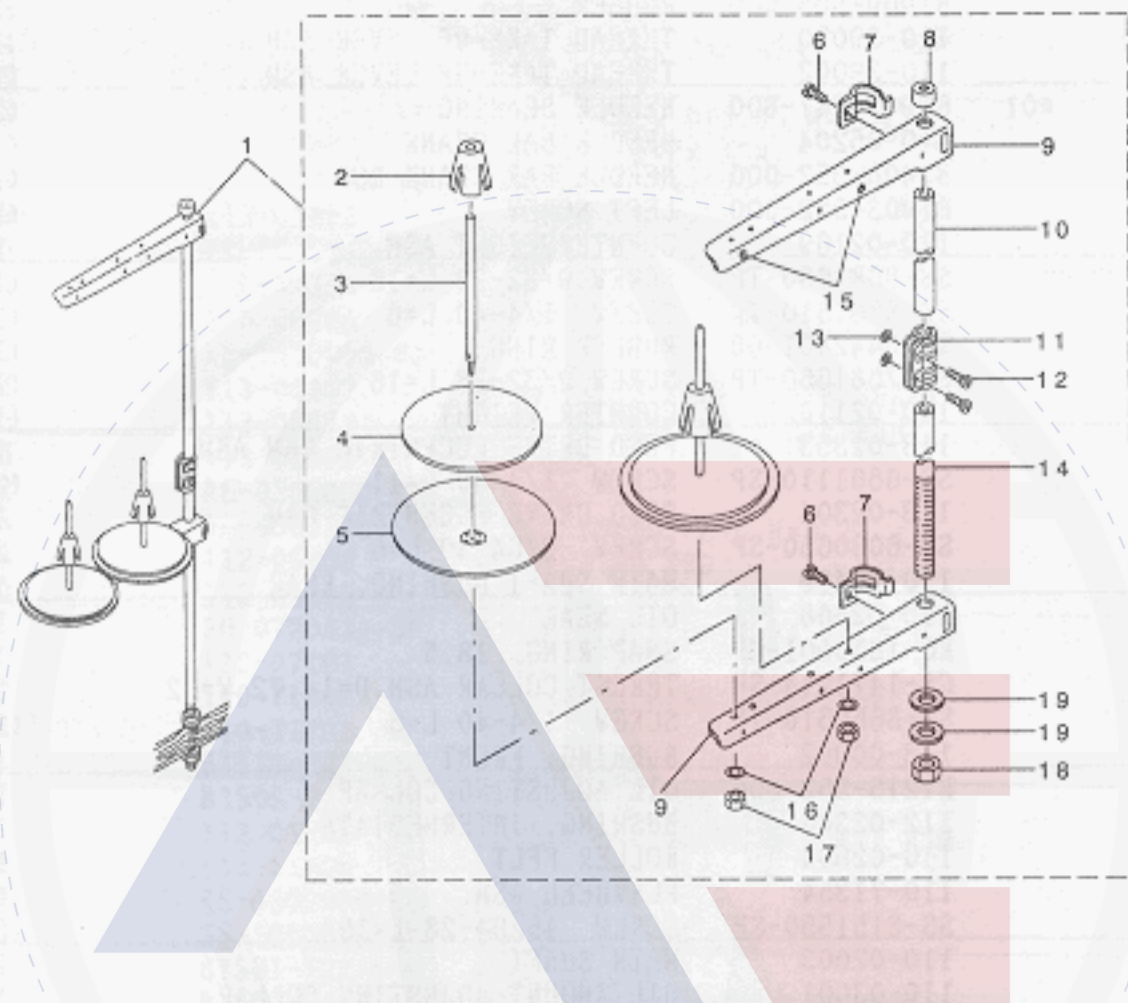

REF.NO	NOTE	PART NO.	DESCRIPTION	Qty
1		229-30358	THREAD STAND ASM.	1
2		229-31109	SPOOL RETAINER	(2)
3		229-31000	SPOOL PIN	(2)
4		229-30903	SPOOL REST CUSHION	(2)
5		229-30804	SPOOL REST	(2)
6		SM-6061610-SC	SCREW M6 L=16	(2)
7		229-30705	THREAD GUIDE ARM JOINT	(2)
8		229-31406	SPOOL REST ROD RUBBER CAP	(1)
9		229-30507	SPOOL REST ARM	(2)
10		229-30408	SPOOL REST ROD, UPPER	(1)
11		229-31307	SPOOL REST ROD JOINT	(1)
12		SM-4051405-SE	SCREW M5 L=14	(2)
13		NM-6050001-SE	NUT M5	(2)
14		229-30309	SPOOL REST ROD, LOWER	(1)
15		229-31208	THREAD GUIDE	(2)
16		WS-0510002-KN	SPRING WASHER	(2)
17		NM-6050001-SE	NUT M5	(2)
18		NM-6160511-SE	NUT M16X1.5	(1)
19		WP-1702600-S0	WASHER 17X30X2.6	(2)

# 11. EXCLUSIVE PARTS FOR DLN-5410NH

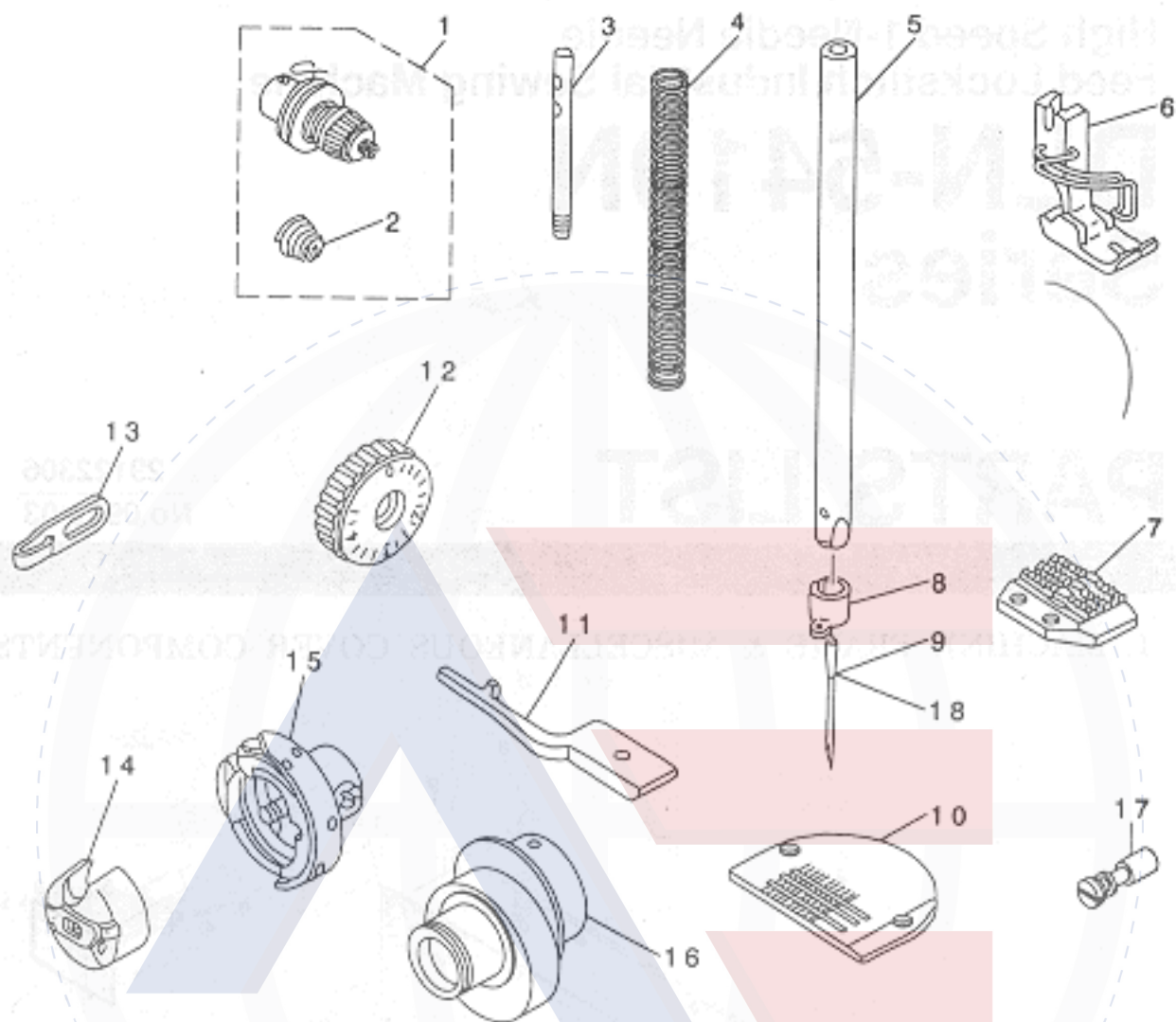

REF.NO	NOTE	PART NO.	DESCRIPTION	Qty
1		110-73558	THREAD TENSION ASM.	1
2		B3114-232-000	THREAD TENSION SPRING	(1)
3		B1114-012-000	THREAD GUIDE PIN	1
4		B1505-552-000-A	PRESSER SPRING	1
5		113-20801	NEEDLE BAR	1
6		B1524-041-EB0	PRESSER FOOT ASM.	1
7		113-22203	FEED DOG, H	1
8		B1418-415-H00	NEEDLE BAR THREAD GUIDE	1
9		HDB-100B2100	NEEDLE DBX1 #21	1
10		B1109-415-H0B	THROAT PLATE (H)	1
11		110-91709	POSITIONING FINGER	1
12		113-26303	FEED DIAL	1
13		110-91006	ARM THREAD GUIDE (HA)	1
14		110-38759	BOBBIN CASE ASM.	1
15		113-21452	LUBRICATING BOBBIN ASM.	1
16		113-22401	FEED ECCENTRIC CAM H	1
17		B1213-552-000-A	OIL ADJUSTING PIN	1
18	#01	MC-2005014-00	NEEDLE 134 140	1

Note #01....FOR JE

## 12. EXCLUSIVE PARTS FOR DLN-5410NL

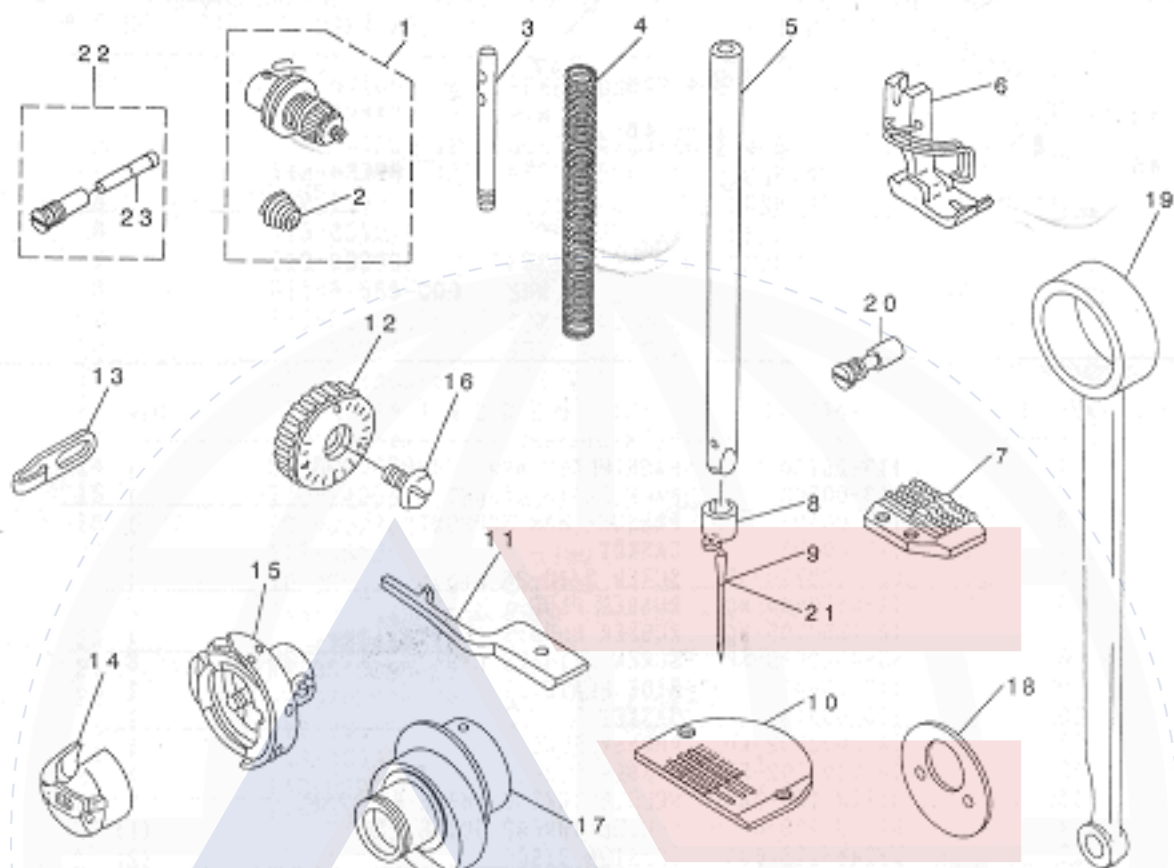

REF. NO	NOTE	PART NO.	DESCRIPTION	Qty
1		110-73558	THREAD TENSION ASM.	1
2		B3114-232-000	THREAD TENSION SPRING	(1)
3		B1114-012-000	THREAD GUIDE PIN	1
4		B1505-552-000-A	PRESSER SPRING	1
5		113-20801	NEEDLE BAR	1
6		B1524-415-LBO	PRESSER FOOT ASM.	1
7		113-22203	FEED DOG, H	1
8		B1418-415-H00	NEEDLE BAR THREAD GUIDE	1
9		MDB-100B2100	NEEDLE DBX1 #21	1
10		B1109-415-H0B	THROAT PLATE (H)	1
11		110-91709	POSITIONING FINGER	1
12		113-26451	FEED DIAL ASM.	1
13		110-91006	ARM THREAD GUIDE (HA)	1
14		D1837-415-DAL	BOBBIN CASE ASM.	1
15		113-21452	LUBRICATING BOBBIN ASM.	1
16		SS-6121050-SP	SCREW 3/16-28 L= 9.5	1
17		113-24001	FEED DRIVE ECCENTRIC CAM	1
18		113-24209	THRUST COLLAR	1
19		113-24100	ROCKER SHAFT CONNECTING ROD	1
20		B1213-552-000-A	OIL ADJUSTING PIN	1
21	#01	NC-2005014-00	NEEDLE 134 140	1
22		114-04753	OIL SEAL SCREW	1
23		114-04704	OIL WICK	(1)

Note #01...FOR JE